

INSTALLATION INSTRUCTIONS:

NOTE: A UT-2019 is required for these installation instructions.

STEP 1: Assemble the UT-2019-KIT to the universal tray as per the UT-2019-KIT installation instructions. However, do not install the rear fences.

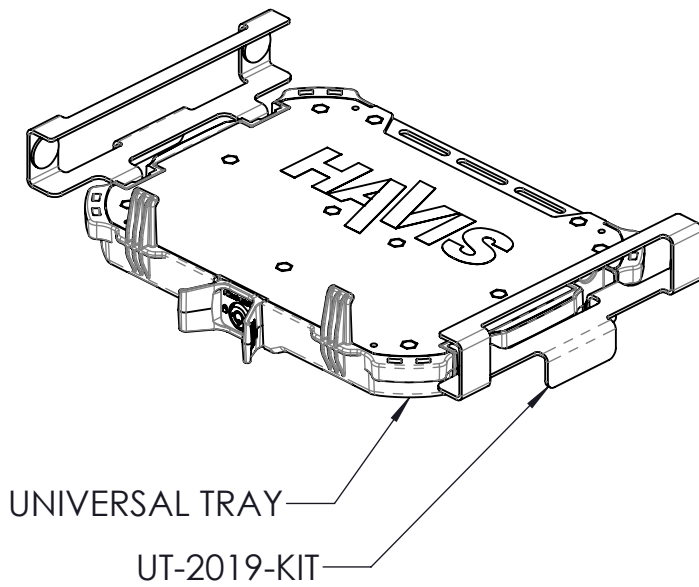

STEP 2: Position the DS-DA-251 keyboard support behind the universal tray.

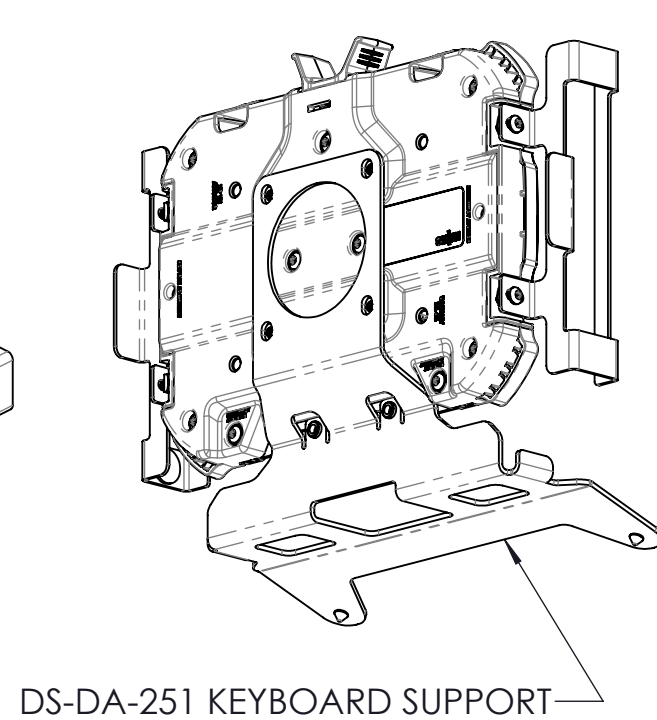

STEP 3: Attach the DS-DA-251 keyboard support using the supplied two Torx screws and serrated washers.

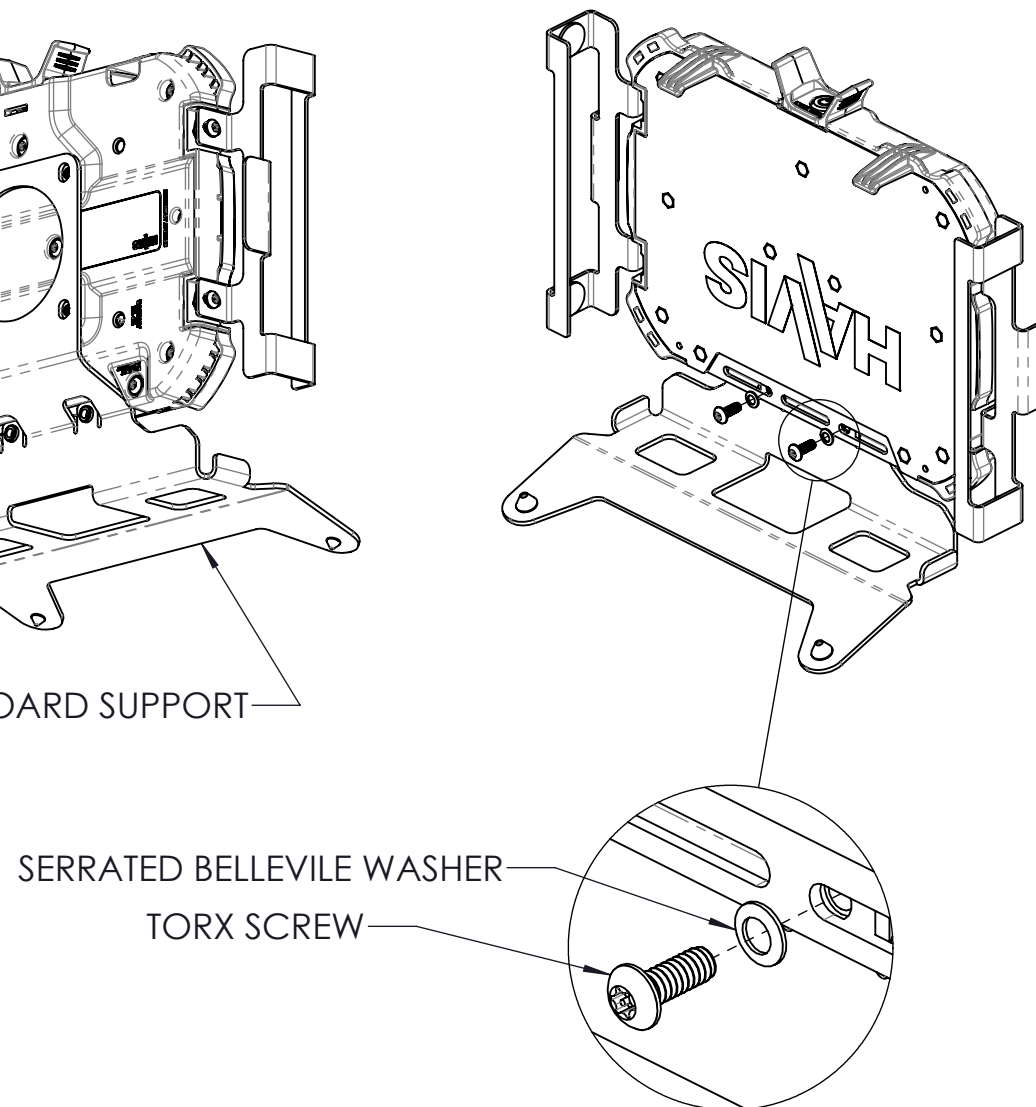

STEP 4: Attach the universal tray and keyboard support to desired mount. **Make sure to use the 16mm Phillips screws supplied with the DS-DA-251.**

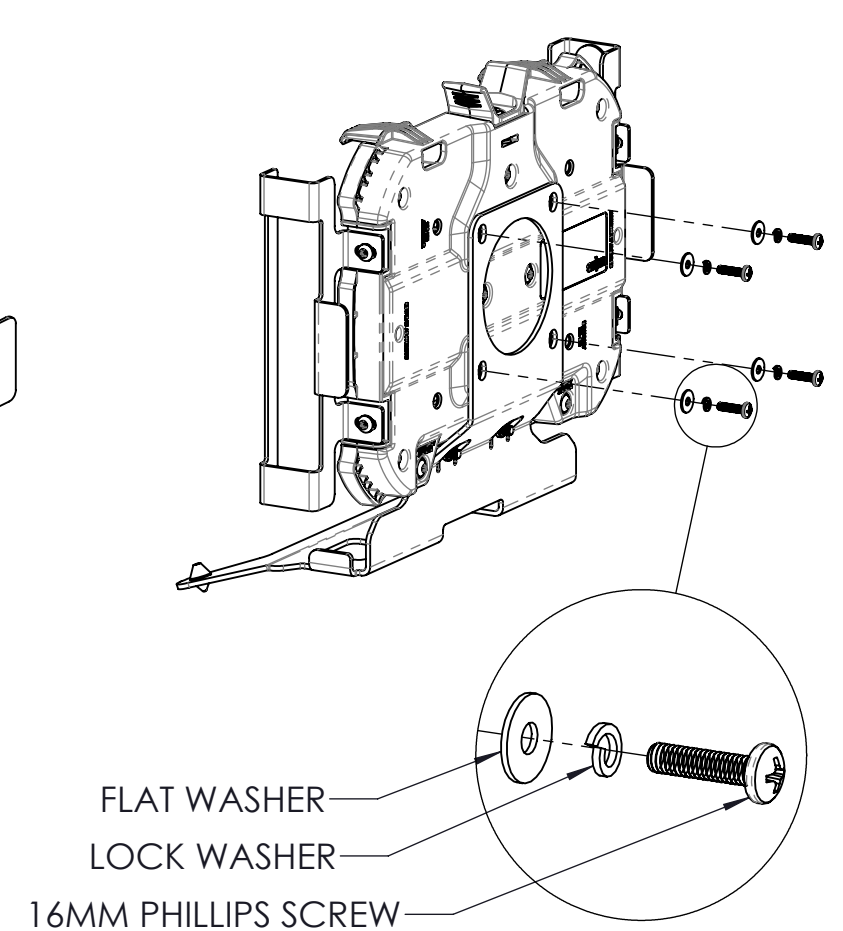

HARDWARE KIT CONTENTS:

QTY.	DESCRIPTION
4	FLAT WASHER, M4, 0.9mm to 1.1mm THICK
4	LOCK WASHER, M4, 7mm OD, 1.1mm MIN THK
4	PHILLIPS SCREW, M4X0.7X16
2	SERRATED BELLEVILLE WASHER, #10
2	TORX SCREW, #10-32x0.5

WARNING: ALL HAVIS INC. PRODUCTS ARE DESIGNED WITH SAFETY OF USE AND INSTALLATION IN MIND. HOWEVER, IT IS THE SOLE RESPONSIBILITY OF THE OWNER/OPERATOR OF A VEHICLE USING HAVIS INC. MOUNTING AND DOCKING EQUIPMENT, TO INSURE THAT THE EQUIPMENT IS INSTALLED SO THAT IT WILL NOT INTERFERE WITH VEHICLE OPERATION, INTERFERE WITH SAFETY DEVICES, OBSTRUCT VIEW OF DRIVING CONDITIONS, OR IN ANY WAY DEGRADE OCCUPANT SAFETY. IMPROPER INSTALLATION CAN CAUSE SERIOUS INJURY IN THE EVENT OF AN ACCIDENT. INSTALLATION SHOULD ONLY BE PERFORMED BY QUALIFIED PROFESSIONALS. COMPUTERS AND MOTION DEVICES MUST BE MOVED TO AND STOWED/SECURED IN THEIR SAFE DRIVING POSITIONS BEFORE OPERATING VEHICLE.

DRAWING NO.

DS-DA-251_INST_11-22

PRODUCT DESCRIPTION

**DS-DA-251, KEYBOARD
SUPPORT BRACKET FOR DELL
7230**

HAVIS

1-800-524-9900
WWW.HAVIS.COM

WEIGHT: (LBS)

4.285

REV. DATE

11-21-22